

PCM-6D

Intelligent Input/Output Module

Description

PCM-6D input/output module is an intelligent addressable four-wire wiring configuration.

The module has two channels, single output and single input. Two independent LED indicators indicate the status of the two channels respectively. The indicators can be in blinking normal operation, steady on or off state according to the command issued by the fire alarm system.

The input channel monitors a passive switching signal input and feeds its status back to the controller. When normal communication, the indicator light is steady on, when short circuit, the indicator light can be extinguished when special needs.

The output channel controls the output of a 24V DC power supply. The DC power supply circuit is electrically isolated from the communication circuit. The output channel can monitor the power failure state, and the supervised end-of-line resistor can monitor for normal, open, short circuit state of the output loop connection line and feedback to the controller. The indicator light is blinking when normal communication, always steady on when activated, and can be extinguished when special needs.

The communication line and power line of the module adopt non-polarity wiring design, which is convenient for on-site wiring installation.



Specifications

Rated Voltage: DC24V.

Standby Current: 430µA@DC24V.

External Supply Voltage: DC24V.

Standby Current: 1.3mA@DC24V.

Action Current: 2A@DC30V.

Operating Temperature: -10°C ~ 55°C.

Operating Humidity: 5% ~ 95%RH Non-condensing.

Dimension: 85mm×85mm×35mm (Including base).

Weight: 65g.

Software Version: A.

Carried Standard: GB 16806-2006.

Addressing

PCM-6D is an intelligent module, each module in the loop must be uniquely addressed, its address is set by address coder/decoder handheld programmer CP600M, address range: 1~230.

The written address N is the address of the output channel. The module automatically generates N+1 as the address of the input channel.

Please refer to the CP600M instructions for specific operations.

Terminal Description

PCM-6D intelligent input/output module is used with M600-8T terminal base for PCM-6/PCM-6D, and its wiring terminals are defined as follows:

L1	Communication	O+	Output +
L2	Communication	VI1	Power
K1	Input	VI2	Power
K2	Input	NO	No
COM	Output -	O-	No

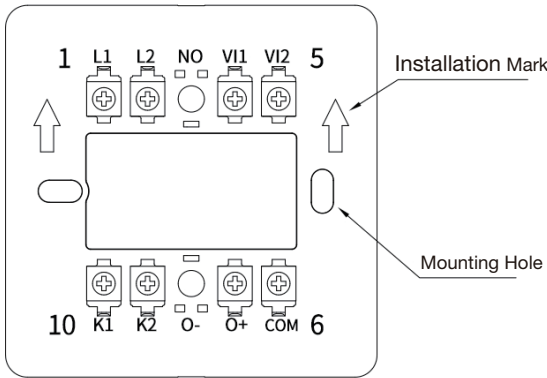

Figure 1: M600-8T Terminal Base for PCM-6/PCM-6D

Power Supply and Wiring

Power supply instruction

The design of the system is determined by calculated number of modules allowed in the loop according to the load capacity of the controller or power supply, ensuring that the sum of the current consumed by all devices in the loop does not exceed the load capacity of the controller or power supply. In the loop calculation, it is necessary to consider the voltage drop caused by the resistance of the line.

Resistance of general wiring sizes

- 1.0 mm² 19.5Ω/1000m
- 1.5 mm² 13.3Ω/1000m
- 2.5 mm² 7.98Ω/1000m

For example, if there are 10 devices in a certain area and each device needs 10mA, connect them with 1.5mm² lines of 2000m (total line length = line length in operation + line length returned), and the current at the end of the line is 10mA, then: Number of devices x terminal current x (total length of lines x wire resistivity) = voltage drop, 10 x 10 mA x (2000m x 13.3 ohms /1000m) ≈ 2.7V

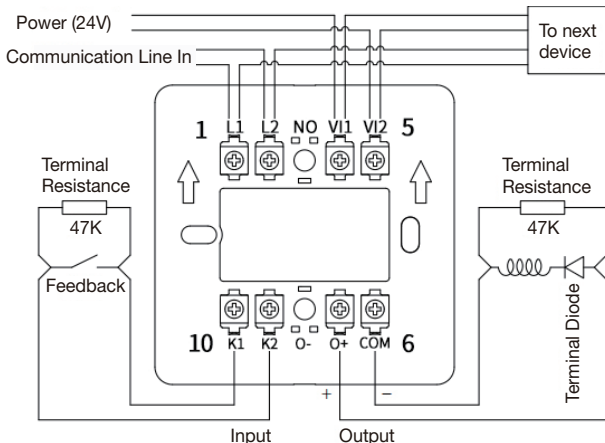

Figure 2: Wiring Diagram

Wiring

PCM-6D intelligent input/output module is used with M600-8T terminal base for PCM-6/PCM-6D, wiring as shown in Figure 2.

Communication line and power supply for non-polarity, do not distinguish between positive and negative poles. The output needs to distinguish between positive and negative poles.

Mounting

Install the base at the predetermined installation position according to the direction indicated by the installation mark (Figure 1) on the M600-8T terminal base.

Disconnect the power supply of the loop and wire according to the wiring diagram (Figure 2).

Use the address coder/decoder handheld programmer CP600M to address the module.

Align the hook on the module with that on the base, press into the mounting base (Figure 3), and the installation is complete.

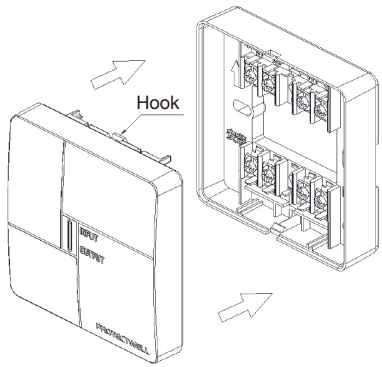

Figure 3: Mounting

Remove

As shown in Figure 4, insert the straight screwdriver into the removal hole and pry the base with moderate force in the direction of the arrow until the latch is released. Repeat this operation on the opposite side to remove the module.

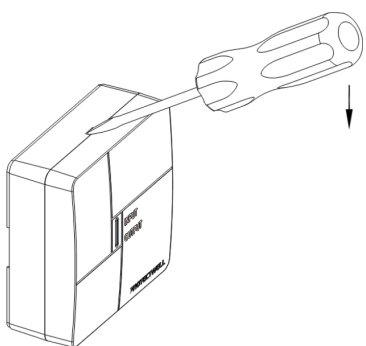

Figure 4: Remove

Ordering Information

- PCM-6D:** Intelligent Input/Output Module.
- PCM-6D/C*:** Intelligent Input/Output Module.
(CLIP model for legacy system).
- M600-8T:** Terminal Base for PCM-6/PCM-6D.
- NOTE:** "IC" is ordering suffix and will not show on product label.